

Tenite™ cellulosic plastics

Secondary fabrication techniques

Plastics made from wood pulp—a renewable resource

Introduction

Articles manufactured of plastics frequently require some type of secondary operation to remove minor imperfections, to develop desired surface characteristics, or to provide assembly or decoration. These operations fall into two broad categories: (1) machining and finishing and (2) decorating and assembling. Each plastic has unique properties and characteristics that need to be considered when subjecting it to the various types of secondary operations. This brochure is intended as a guide for using secondary operations on articles made from Eastman cellulosic plastics—Tenite™ cellulose acetate, Tenite™ cellulose acetate butyrate, and Tenite™ acetate propionate. It includes suggestions for removing gates, flash, or rough surfaces, and for machining, finishing, decorating, and assembling.

Mechanical operations

Trimming gates from molded articles

The size of individual molded articles, the number of molded articles per shot, and the size and location of the gate usually govern the gate-trimming method used.

When the article is large and heavy enough to break the gate in handling, when the gate is on a nonappearing surface, or when there are only a few articles per shot, it is common practice for the operator to hand cut the gates with side-cutting pliers or pruning-type cutters at the molding machine. Subsequently, a milling cutter is sometimes used for final trim, particularly with heavy gates.

For multipiece shots, or when a close trim is desired, normal practice is to use a hand-, kick-, or punch-type press with a positioning fixture. For best appearance of the cut, cutting pressure should be applied from both sides of the gate, not from one side alone. This will also prevent the gate from breaking into the body of the molded article. One cutting blade can be stationary and

the other movable, and in the closed position, they should be spaced approximately 0.051 mm (0.002 in.) apart. Blade movement is controlled by adjustable stops in the press. Both blades should be hollow ground on the side away from the molded article for a shearing blade as illustrated in Figure 4. The blades are sometimes heated when an exceptionally smooth cut is desired.

For cutting thick gates such as those sometimes used for molding items such as heavy screwdriver handles, using a band saw or circular saw is the usual practice, followed by finishing on a milling cutter. If desired, milling can be followed by a buffing operation.

Another gate-trimming method uses a conventional band saw blade from which the teeth have been ground and the blade beveled at about a 30° angle. Such a blade, when mounted on a band saw and operated at a speed of 366 to 1,220 m (1,200 to 4,000 ft) per minute makes a smooth cut. At 1,220 m (4,000 ft) per minute, the blade both saws and burns through the gate, and some melted plastic collects on the underside of the cut surface—more on the beveled side than on the flat side of the blade. The cut has a polished surface, and little, if any, additional finishing is required. The same results are obtained at slower blade speeds, but cutting takes longer. For best results, determine the blade speed by trial for each job.

Machining

Tenite™ cellulosic plastics can be worked with most tools used for machining wood or metal. Tool speeds should be such that the plastic material does not melt from frictional heat. In general, the highest speed at which overheating of the tool or plastic does not occur will give best results.

It is important to keep cutting tools sharp at all times; hard, wear-resistant tools with greater cutting clearances than those used for cutting metal are suggested. High-speed or carbon-tipped tools are efficient and economical, especially for long runs.

Because plastics are poor heat conductors, the heat generated by machining operations must be absorbed by the tool or carried away by a coolant. A jet of air directed at the cutting edge aids not only in cooling the tool but also in removing chips. Not all oils are chemically compatible with cellulosic plastics. Check with your Eastman representative for a list of compatible oils. Oil, soapy water, and plain water also promote a smooth cut and are sometimes used for cooling. These coolants cannot be used, however, if trim scrap is to be reused. Trim scrap contaminated with oil or other foreign matter cannot be molded satisfactorily.

Drilling

Drills designed especially for plastics are available, and their use is suggested for drilling cellulosic plastics; however, standard twist drills used for drilling metal or wood are often satisfactory.

Twist drills for plastics should have two flutes, a point with an included angle of 60° to 90° , and a lip clearance of 12° to 18° , as shown in Figure 1. Wide, highly polished flutes are desirable because they expel the chips with less friction and thus tend to avoid overheating and consequent gumming. Drills with substantial clearance on the cutting edge of the flute make a smoother hole than those with less clearance. Drills should be backed out often to free chips, especially when drilling deep holes. Peripheral speed of twist drills for plastics ranges from 30.5 to 61 m (100 to 200 ft) per minute. The rate of drill feed into the plastic varies from 0.254 to 0.64 mm (0.010 to 0.025 in.) per revolution. The plasticizer level of the plastic governs the drill speed and feed rate that should be used. High speeds and high feed rates are used for high plasticizer level materials; low speeds and low feed rates are used for low plasticizer level materials.

To drill a clean hole and keep the material from gumming, twist drills used for metal require much slower speeds and feed rates than those designed for plastics. Also, the drill must be backed out more frequently to clear chips.

Figure 1 Suggested drill-point design for drilling cellulosic plastic

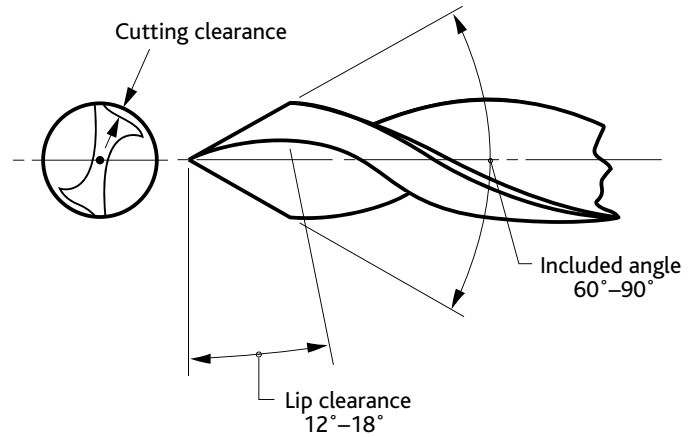

Reaming

Reaming holes drilled in articles made of acetate, butyrate, and propionate is not recommended. Where close tolerances are required in thin sections, good results can be obtained by drilling to within 0.025 mm (0.001 in.) of desired size, then pushing a hardened, polished rod through the hole to obtain a smooth surface.

Tapping internal threads

Conventional 4-flute taps can be used for cutting internal threads when close fits are required. Such taps, however, have a tendency to generate considerable heat during the tapping operation.

A high-speed steel, 2-flute tap, as shown in Figure 2, can provide longer life and greater tapping speed than a conventional tap. The 2-flute tap provides greater clearance for chip discharge. Flutes should be ground so that both cutting edges cut simultaneously; otherwise the thread will be ragged and rough. Cutting edges should be 85° from the center line, giving a negative rake of 5° on the front face of lands so that the tap will not bind in the hole when it is backed out. Some relief on the sides of threads is desirable. Taps should have a 2-thread-taper cutting lead. Either the tap or the work should be free to center.

Figure 2 2-Flute tap for internal threads

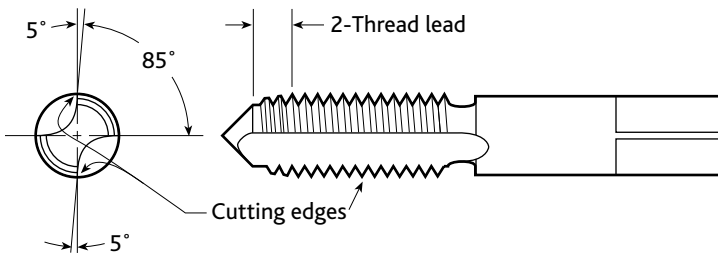

Die cutting external threads

For cutting external threads in cellulosic plastics, a die with 3 flutes or cutting edges is suggested. An example is shown in Figure 3. The details of the cutting edges are the same as for taps. The die or the work should be free to center.

Figure 3 3-Flute die for external threads

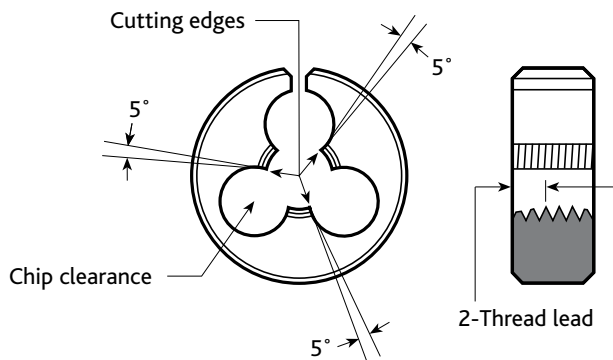

Lathe operations

Tenite™ cellulosic plastics can be readily turned or threaded on a lathe. In general, turning speed should be as high as practical because at low peripheral speeds cuttings tend to form long threads that coil around the work. At high peripheral speeds, centrifugal force causes the thread cuttings to be thrown away from the work. The maximum satisfactory lathe speed is ordinarily about 700 rpm.

A satisfactory rate of feed of the cutting tool into the plastic is about 0.30 mm (0.012 in.) per revolution; rough surfaces often result when the feed rate is as much as 0.64 mm (0.025 in.) per revolution.

The maximum depth of cut for a smooth surface varies with peripheral speed and the flexibility of the plastic stock. At a peripheral speed of 84 m (275 ft) per minute, no appreciable variation of surface finish can be noticed when the depth of cut is increased from 0.51 to 3.8 mm (0.020 to 0.150 in.). At peripheral speeds higher than 84 m (275 ft) per minute, smooth surfaces can be obtained with feed rates of 0.30 mm (0.012 in.) per revolution and cuts up to 5.1 mm (0.200 in.) in depth. If the feed rate was increased to 0.64 mm (0.025 in.) per revolution, however, a rough surface would likely result.

Excellent threads may be machined with a standard V-shaped tool as used for metal. Cuts of 0.18 to 0.25 mm (0.007 to 0.010 in.) should be used for final thread forming. Deeper cuts can be used for roughing out the threads.

Milling operations

Tenite™ cellulosic plastics can be machined satisfactorily with standard high-speed milling cutters used for metal if the cutters have sharp edges and adequate clearance at the heel. Tolerances can be easily held to 0.051 mm (0.002 in.) with the following approximate maximum cutting speeds listed at bottom of page.

Sawing

Tenite™ cellulosic plastics can be sawed with any saw used for wood or metal—circular saws, band saws, saber saws, jigsaws, hacksaws, or handsaws. Some of these saws, however, are better suited for sawing plastics because they produce smoother or faster cuts than others. Circular saws and band saws usually produce the best surfaces, and they can be used in most sawing operations.

	Plastic	
	High Plasticizer Levels	Low Plasticizer Levels
Cutter diameter, mm (in.)	76 (3.0)	76 (3.0)
Cutter speed, rpm	400	274
Peripheral speed, m/min (fpm)	95.7 (314)	65.8 (216)

Tenite™ cellulosic plastics Secondary fabrication techniques
 Plastics made from wood pulp—a renewable resource (Continued)

Blade design plays an important part in successful sawing of plastics. Band saw blades must have set teeth for any type of sawing, but for curved cuts, the blade should be narrower and have more set teeth than a blade used for straight cuts. The blade should be just soft enough to permit filing, and it must be kept sharp to prevent melting or chipping of the plastic. The blade guide should be placed as close as possible to the material being cut.

For straight cuts, a circular saw, even though it tends to generate more heat than a band saw, is preferred because it produces a smoother cut. A perforated saw blade will run cooler than a solid blade. It is essential that the spindle bearing of a circular saw be tight so that the saw will run true. The saw should be hollow ground with no set to the teeth. For best results, the tooth pitch should be to the center of the arbor hole with a well-rounded gullet to permit free curling and ejection of chips.

For cutting a section 9.53 mm (3/8 in.) thick or less, a saw with 3.2 teeth per cm (8 teeth per in.) is suggested. For cutting a thicker section, a saw with 2.4 teeth per cm (6 teeth per in.) is more satisfactory. The spindle speed should be approximately 3,000 rpm, which represents a peripheral speed of about 1,829 meters (6,000 ft) per minute for a 20.3-cm (8-in.) saw. The faster the saw can be forced into the material, the cleaner the cut and the longer the saw life.

A clean cut with minimum breakage or chipping after cutting through the plastic may be obtained by using a cross-cut circular saw operated at maximum speed. The saw should have radial teeth in sets of 4, ground as follows: first, a straight-ground chisel tooth with edge parallel to the axis; second, a tooth ground with the right point high; third, another straight tooth; fourth, a tooth ground with the left point high. The straight teeth, or teeth 1 and 3, should be 0.025 mm (0.001 in.) lower than the taper-ground teeth.

With a small variable-speed band saw having a 6.35-mm (1/4-in.) wide blade with 1.6 teeth per cm (4 teeth per in.), with the teeth set and run in the usual manner, and with a maximum blade travel of 457 m (1,500 ft) per minute, the rates of feed tabulated in the following table should produce a good, smooth-cut surface.

Thickness of material mm (in.)	Plasticizer level of material	Feed rate m/min (in./min.)
51 (2.0)	Low	1.8 (70)
51 (2.0)	High	2.4 (94)
25 (1.0)	Low	3.0 (120)
25 (1.0)	High	3.6 (140)
6.4 (1/4)	Low	7.6 (300)
6.4 (1/4)	High	8.7 (343)

Slower blade speeds than those listed normally do not give any better results. If plain or soapy water is used as a coolant, the feed rate can be increased but there is no improvement in the surface of the cut. On 51-mm (2-in.) material with low plasticizer level, the feed can be increased to 3.4 m (132 in.) per minute with a plain water coolant and 3.3 m (130 in.) per minute with a soapy water coolant. This method of increasing the feed rate is not practical if scrap is to be reused. Using compressed air as a coolant will not alter the results; however, for extended sawing operations, the use of compressed air is suggested.

In general, Tenite celluloseics can be sawed with or without using saw coolants. However, higher cutting rates can be obtained when coolants are used. Following are blade speeds, material feed rates, and blade types that can be used for sawing these plastics when a coolant consisting of 1 part water-soluble oil and 4 parts water is used.

Material thickness mm (in.)	Blade type	Saw teeth per cm (in.)	Saw speed m/min (fpm)	Material feed rate
Up to 6.4 (1/4)	Precision	4.0 (10)	1,372 (4,500)	Low
6.4–12.7 (1/4–1/2)	Precision	2.4 (6)	1,036 (3,400)	Low
12.7–25.4 (1/2–1)	Precision	1.6 (4)	762 (2,500)	Low
25.4–76.2 (1–3)	Buttress	1.2 (3)	549 (1,800)	Low
76.2–152.4 (3–6)	Buttress	1.2 (3)	457 (1,500)	Medium

Tenite™ cellulosic plastics Secondary fabrication techniques
 Plastics made from wood pulp—a renewable resource (Continued)

In making curved cuts with a band saw, using the correct blade width is essential. Following is a list of the minimum cutting radius for several blade widths.

Blade width mm (in.)	Minimum cutting radius mm (in.)
25.4 (1)	184 (7 ¼)
19.1 (¾)	138 (5 ⅞)
15.9 (⅝)	95 (3 ¾)
12.7 (½)	64 (2 ½)
9.5 (⅜)	36 (1 ⅞)
6.4 (¼)	16 (⅝)
4.8 (⅜)	7.9 (⅝)
3.2 (⅛)	3.2 (⅛)
2.4 (⅜)	2.4 (⅜)
1.6 (⅛)	Saw cut width and blade width equal. Square turns can be made.

Shearing, blanking, and punching

Sheets of Tenite acetate, Tenite butyrate, and Tenite propionate can be sheared, blanked, or punched with sharp-edge cutting tools. In any of these operations, warming the sheet is essential if a smooth-cut edge is to be obtained. The greater the thickness of the material, the higher the warming temperature required. However, the material should not be heated to the point that its lustrous surface is damaged.

When a sheet of plastic is heated, it is softened and the pressure required to shear, blank, or punch the sheet slightly compresses the material. After the pressure is released from the warm material, the sheet expands to its original size, leaving one edge slightly concave and the other convex. In shearing, blanking, or punching, it is virtually impossible to obtain both a smooth cut and a straight edge at the same time, particularly on a thick sheet. The curved edges are scarcely noticeable on sheet less than 2.54 mm (0.100 in.) thick. A diagram of a shearing assembly is shown in Figure 4; Figure 5 shows a blanking and punching assembly.

Figure 4 Shearing Assembly

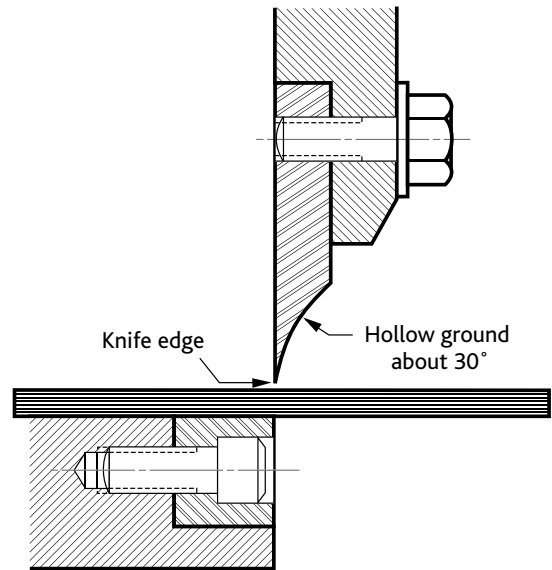
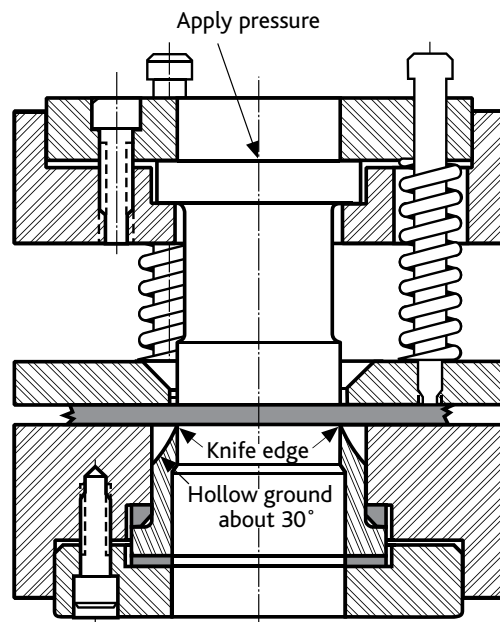

Figure 5 Blanking and Punching Assembly



Surface finishing

Sanding

Tenite™ cellulosic plastics may be sanded in production operations on machines made for this purpose. Both bench and upright types of these machines have an endless abrasive belt that runs at a speed of approximately 610 m (2,000 ft) per minute. Both coarse and fine abrasive belts are used. Frequently, preliminary sanding is done on a coarse belt and final sanding on a fine belt. To avoid gumming of the material through overheating, the work should be pressed only lightly against the belt. It is often desirable to sand one piece partially, then go to the next, and so on, coming back to the first piece after it has cooled.

Wet sanding is sometimes desirable, and a satisfactory finish can be obtained by using grade No. 000 sandpaper with the belt running about 457 m (1,500 ft) per minute.

Wheel polishing and buffing

Articles molded of Tenite acetate, butyrate, and propionate come from the mold with a surface polish equal to that of the mold cavity. Because it is economical to have a brilliant, mirror-like surface on most molds, postmolding finishing operations are usually not needed on injection molded items. Wheel polishing and buffing are normally used in finishing machined models.

Buffing, unlike ashing or lapping, does not abrade the plastic surface but causes a minute surface flow of the material.

Polishing of molded articles, if done at all, usually consists merely of an easy wipe against a relatively soft buffing wheel to impart a final lustrous surface. A relatively hard wheel is used for polishing flash lines and gates.

Wheel polishing is done on a buff made of muslin disks about 305 mm (12 in.) in diameter. The hardness of these disks is regulated by the use of spacers, as described in the following section on ashing. With a hard wheel, it is often necessary to use disks of smaller diameter to get into depressions and to avoid “burning” the edges of recessed areas. Polishing wheels are run at about 1,200 rpm.

Ashing, rubbing, and lapping

Articles molded of Tenite acetate, butyrate, and propionate seldom need to be ashed or lapped. These operations may be necessary, however, for erasing tool marks from areas where large gates have been removed or from models machined from blocks of plastics.

Ashing produces a dull-luster, satiny finish on the surface of cellulosic plastics, and subsequent polishing is required to achieve a bright lustrous finish. Ashing is done on the periphery of a wheel built of muslin disks, preferably not sewn together. Loose disks rather than disks sewn together permit the wheels to be changed in hardness by adding or removing spacers (smaller muslin disks). Hard or soft ashing wheels can be used depending on the type of work and the speed of abrasion desired. A soft wheel is made by placing spacers between the muslin disks that form the working surface of the wheel. Even a relatively hard wheel frequently has one spacer to every two disks; a somewhat softer wheel has two spacers to two disks. The width of wheels can be varied. Wheels that have become worn may be disassembled, and the disks used for spacers if they are not sewn together.

The ashing wheel is usually 102 to 152 mm (4 to 6 in.) wide, 305 to 356 mm (12 to 14 in.) in diameter and is run at a speed of approximately 1,200 rpm. Spacers are about 152 mm (6 in.) in diameter. Where a greater and quicker abrasion is desired, a corn husk or carpet wheel is used; the operation is then termed “rubbing.”

Wet pumice, usually grade 0½, 1, or a mixture of the two grades, depending on the abrading action desired, is applied to the periphery of the ashing wheel. Wetting the pumice accelerates cutting and retards excessive dusting. The plastic article should be washed as soon as it is ashed, then dried promptly.

Because the ashing wheel flings off wet pumice during operation, it is usually fitted with an open-front metal hood. The opening, which exposes the work surface of the wheel, should be large enough to allow easy manipulation of the plastic article. The bottom part of the hood catches the wet pumice as it falls from the wheel and serves as a reservoir for the abrasive compound.

Tenite™ cellulosic plastics Secondary fabrication techniques
 Plastics made from wood pulp—a renewable resource (Continued)

Lapping is similar to ashing; however, a different type of wheel is used, and the work is done on the side of the wheel instead of on the periphery. A lapping wheel consists of a flat metal disk 254 to 305 mm (10 to 12 in.) in diameter mounted on the end of an arbor or shaft. Heavy felt is cemented to the surface of the flat metal, and wet pumice is added to this. The flat piece of plastic to be lapped is pressed against the surface.

Like ashing wheels, lapping wheels are usually hooded. Since the operator works at the side of the wheel, the hood can extend entirely around the periphery of the wheel. Lapping wheels are run more slowly than ashing wheels, at about 400 rpm.

Tumbling

Flash is seldom removed from cellulosic plastics by tumbling. Because Tenite™ cellulosic plastics are so tough, if they are tumbled to remove flash, the surface of the entire article becomes abraded and must be polished. However, the addition of dry ice to the tumbling barrels causes flash to become relatively brittle, and in some cases, a short period of tumbling can be used to remove thin flash without serious impairment of the surface finish of the molded article.

When tumbling is used for abrasion purposes, wet rottenstone and pumice mixed with small stones or balls to add weight are usually employed. For tumble polishing, jeweler’s rouge and special polishing compounds are used, mixed with sawdust, leather scrap, wood pegs, etc. This is a specialized operation. Several companies supply equipment and procedures for obtaining the best results in individual applications.

Solvent polishing

An effective method of eliminating fine surface scratches and producing a high gloss on cellulose plastics is solvent polishing. The article is usually dipped into a suitable solvent and then suspended to dry. The dipping time should be as short as possible; usually, simply wetting the surface with an even film of solvent is all that is required. If a quick-drying solvent is used, it is often necessary to add a small amount of a slow-drying component to prevent humidity blush after drying.

When an article that has excessive surface strains or internal strains is dipped into an active solvent, the surface may become rough. This type of rough surface is commonly referred to as “orange peel,” and it is more prevalent on injection-molded items than on extruded or compression-molded items. If an article is to be solvent polished, spot check on a hidden area to determine whether enough strains are present to cause orange peel.

Some solvent mixtures that have been used successfully for dip polishing Tenite acetate, butyrate, and propionate articles follow.

Tenite acetate	Tenite butyrate and Tenite propionate
70% Acetone 30% Ethyl lactate	70% Isopropyl alcohol 30% Toluene
80% Acetone 20% Eastman PM acetate	80% Acetone 20% Eastman PM acetate
	95% Isopropyl alcohol 5% Eastman PM acetate

NOTE: Since acetone has a high evaporation rate, it will be lost from a solution over long periods of time. The specific gravity of solutions containing acetone should be determined with a hydrometer and maintained as nearly constant as possible by adding acetone from time to time.

Another effective method of polishing cellulosic plastics is to wipe them with a cloth wet with one of the solutions listed above. The cloth should be saturated with the solution before wiping each article. One advantage of this method is very short drying time.

Some molders use a solvent-vapor method of polishing molded articles: a solution, such as 69% ethyl acetate and 31% ethyl alcohol, is vaporized, and the molded article is passed through the vapors. Adequate ventilation and appropriate personal protective equipment (PPE) should be used to minimize workplace exposure to solvent vapors. Information regarding ventilation requirements and PPE can be found on the manufacturer’s Safety Data Sheet (SDS)

Dull or matte finish

A dull or matte finish on molded articles of Tenite acetate, butyrate, or propionate may be accomplished by imparting a dull or rough surface to the mold cavity or by treating

Tenite™ cellulosic plastics Secondary fabrication techniques

Plastics made from wood pulp—a renewable resource *(Continued)*

the casting subsequent to molding. A dull or rough finish on the surfaces of the mold can be obtained by sandblasting or vapor honing.

In vapor honing, abrasive material is carried by a stream of water that is forced under air pressure through one or more nozzles and against the surface of the mold cavity. The degree of abrasion is determined by the size and speed of the abrasive particles and the duration of treatment.

Vapor honing can also be used directly on the molded article to impart a dull surface finish. In one piece of commercially available equipment, the molded piece is placed in an enclosed chamber and sprayed with a water/abrasive mixture. The water and abrasive are drawn through a Venturi tube by a stream of compressed air and directed against the molded article by means of one or more nozzles. Another method is to place the molded article on a turntable revolving under the nozzle so that all exposed surfaces of the article are honed.

Articles made of Tenite™ cellulose can also be given a dull or matte finish by spraying them with flatting lacquers. Suitable lacquers can be obtained from any of the lacquer manufacturers listed on page 13.

Decorating

Marking

A trademark or brand name can be molded into an article of Tenite acetate, butyrate, or propionate. If a given production run is to carry different imprints, however, an easy and cost-effective alternative to using multiple molds is available: articles made of Tenite™ cellulosic plastics will accept a neat, permanent stamp; stamping plates with different imprints can be replaced as desired, saving the cost of additional molds.

“Blind” stamps, trademarks, and decorative effects can be produced on Tenite cellulosic plastic articles by placing the article to be stamped in a fixture and pressing a hot die, usually brass, against the surface, ordinarily by means of a hand or kick press. When such a trademark or decoration should be plainly visible, the stamping is subsequently filled in with an appropriate lacquer or filling paste. The most satisfactory filling pastes Eastman has tested for use

on Tenite acetate, butyrate, and propionate are those that consist of pigment dispersed in a drying oil.

Colored foils can be hot-stamped permanently into the surface of cellulosic plastics to give beautiful effects. In this method of decorating, a special tape with pigments deposited on its surface is pressed into the surface of the plastic article by a heated printing die. The tape releases the pigment in the depressions made by the hot die, and the heat and pressure fuse the pigment into the plastic surface.

Printing

Articles manufactured from Tenite™ cellulosic plastics may be printed with conventional printing equipment. Special printing inks are required because the ink is not absorbed by the plastics as it is by paper or cloth. Since the ink is not absorbed into the plastic, it is subject to abrasion. The effect of abrasion can be minimized by applying a light coat of clear lacquer over the printing. A partial list of companies manufacturing inks for use on thermoplastic materials follows. Since each application might require a different type of ink, no attempt is made to suggest specific inks. Ink manufacturers prefer to consider each application separately to determine the best ink.

In general, when articles of Tenite acetate, butyrate, or propionate are to be printed, they should be made of the lowest plasticizer level of plastic that will give suitable properties in the finished article. In all applications, the printed article should be tested at 38°C (100°F) and 80% relative humidity for at least 72 hours to determine whether the ink will be softened by plasticizer migration.

Silk screening

The printing of brand names, trademarks, designs, etc. on Tenite acetate, butyrate, and propionate can be done by the use of silk screens like those used in the book- or poster-printing trades.

A silk screen is simply a stencil film supported on a fine silk or similar fabric and held in a wooden frame. Intricate designs and all types of lettering are possible by this method.

Special lacquers and inks are available for silk screening Tenite™ cellulosic plastics.

Tenite™ cellulosic plastics Secondary fabrication techniques

Plastics made from wood pulp—a renewable resource (Continued)

Engraving and etching

Engraving Tenite™ cellulosic plastics is usually done on pantographic-type engraving machines with motor-driven rotary cutters.

Etching is accomplished by blocking out portions of the article that are not to be etched with a resistant material, after which the unblocked section is exposed to a solvent. After the solvent has acted to the required depth and the article is allowed to dry, the etched background may be colored. When the resistant material is removed from the article, the unetched portion is in relief.

Decal companies

The following company can supply special decals that are not adversely affected by plasticizer; however, adhesion may not always be satisfactory on very high plasticizer levels of Tenite™ cellulosic plastics.

- **The Meyercord Company**
365 East North Avenue
Carol Stream, IL 60188
U.S.A.
(1) 630-682-6200

If decals are to be used on high plasticizer levels of Tenite butyrate or Tenite propionate or on high or medium plasticizer levels of Tenite acetate, tests under elevated conditions of 38°C (100°F) and 80% relative humidity for 72 hours should be made.

Metal coatings

Tenite acetate, butyrate, and propionate articles can be molded in intricate designs and coated with metal to achieve effects that are either impossible or less economical to obtain with metal or plastic alone. Used principally to produce a decorative appearance or a highly reflective surface, metal coating also improves certain physical properties. Among these are increased resistance to weather, solvents, abrasion, and heat; increased tensile strength; and lower water absorption. A mirror-like finish can be obtained without the expensive polishing required to obtain the same type of surface on metals; and a plated Tenite™ cellulosic plastic article weighs considerably less than the same part in metal.

High-vacuum metalizing

One method of applying a metal coating to a cellulosic plastic is the high-vacuum metal-evaporation process. Eastman Kodak Company's high-vacuum metalizing process is disclosed in expired U.S. Patent 2,699,402, "Plastics Articles Having Reflecting Surfaces Thereon and Method for Their Manufacture."

Briefly, Eastman Kodak Company's process involves an initial application of a base-coat lacquer on clean articles of Tenite™ cellulosic plastic formulations of as high a plasticizer level as affords adequate impact strength. After the base coat is cured in an oven, the articles are placed in the chamber of a vacuum-metalizing unit where they are coated with a thin film of aluminum or other metal by the high-vacuum metal-evaporation process. Then a protective top-coat solution is applied over the thin layer of metal; after oven curing of this top coat, the articles are ready for inspection and packaging.

Suppliers of coatings for cellulosic plastics include:

- **N.B Coatings**
2701 East 170th Street
Lansing, IL 60438
U.S.A.
(1) 708-474-7000T
www.nbcoatings.com
- **Red Spot Paint and Varnish Co.**
P.O. Box 418
Evansville, IN 47703
U.S.A.
(1) 812-428-9100
www.redspot.com

Other methods. Other methods of applying a metal coating to cellulosic plastics are electroplating, chemical deposition, spraying, and cathode sputtering.

For *electroplating*, the surface to be plated must be made electrically conductive; a bonding coat is applied for this purpose. In a widely used patented process, the plastic article is sensitized with a stannous chloride solution, then immersed in a reducing solution of formaldehyde with ammoniacal silver nitrate. Other chemical reduction

Tenite™ cellulosic plastics Secondary fabrication techniques

Plastics made from wood pulp—a renewable resource *(Continued)*

methods are possible. Well-known methods for producing a conductive base include the application of lacquer or varnish containing metal powder or coating with melted wax followed by dusting with graphite.

Another technique for electroplating Tenite butyrate with thin adherent deposits of metals involves coating the butyrate article with a primer containing ABS plastic. This coating adheres well to butyrate and will accept, with good adhesion, commercially available electroless copper and nickel systems. Tenite butyrate plated by this method is used in specialty item applications where toughness and good processing characteristics are required.

Tenite butyrate formula 438 containing 6% plasticizer (or less) appears to be the best formulation for plating by the various electroless processes. It appears that at least two of the electroless plating systems that are commercially available are patented; therefore, the patent situation should be thoroughly investigated before using any of these systems.

The procedure for electroplating butyrate by the electroless processes involves three basic operations:

- Primer coating
- Preplate operation
- Electroplating

A thin film of primer is applied by spraying the article to be plated. The following primer formulation has worked well in Eastman's tests.

Component	Concentration (Wt%)
ABS resin	10
Acetone	35
Methyl ethyl ketone (MEK)	35
Eastman PM acetate	20

The primer should be cured in an oven at 121°C (250°F) for 10 to 15 minutes to develop maximum film properties and to ensure complete evaporation of solvent from the film.

A conductive coating of copper or nickel is applied in the preplate operation by using one of several available patented electroless processes.

Four processes presently available for preplating plastics are:

- **AKZO NOBEL COATINGS**
1915 Industrial Avenue
Zion, IL 60099
(847) 872-1000
U.S.A.
www.akzonobel.com
- **Enthone-OMI**
P.O. Box 1900
New Haven, CT 06508
U.S.A.
(1) 203-799-4908
- **Macdermid Inc.**
245 Freight Street
Waterbury, CT 06702
U.S.A.
(1) 203-575-5700

After electroless copper or nickel has been deposited, the article can be plated, as if it were metal, with copper, nickel, chromium, and other metals by conventional electroplating techniques.

Metal spraying requires a special spray gun and is limited to low-fusing alloys to avoid softening the plastic. Other metals may be plated over the spray coat. Spray coats ordinarily produce a granular surface.

Cathode sputtering, like high-vacuum metalizing, requires the use of a vacuum chamber. In the sputtering process, the metal to be deposited is the cathode of a high-voltage electrical circuit and the plastic article to be coated is placed on or near the metal anode. High voltage causes the metal to ionize and be deposited on the plastic.

Lacquering

Only lacquers specifically recommended for use on Tenite acetate, butyrate, and propionate should be used for decorating these plastics. Many lacquers appear to be satisfactory when first applied but later may become tacky when subjected to heat and humidity. This is caused by migration of plasticizer from the plastic to the lacquer. When applied to a particular formula and plasticizer level, lacquers that will withstand 72 hours at

Tenite™ cellulosic plastics Secondary fabrication techniques

Plastics made from wood pulp—a renewable resource *(Continued)*

38°C (100°F) and 80% relative humidity without softening or loss of adhesion are considered satisfactory for most applications. If the plastic is to be used under more severe conditions, the lacquered articles should be tested at the expected conditions. Ordinary nitrocellulose- and acrylic-base lacquers are satisfactory for use only with low plasticizer levels of some Tenite acetate formulas and with low and medium plasticizer levels of Tenite butyrate and propionate. The exact plasticizer level limitation will depend on the particular formula of the plastic.

A number of special lacquers are available that may be used with any formula and plasticizer level of acetate, butyrate, or propionate. Special weather-resisting lacquers are available for use on Tenite butyrate applications when resistance to weathering is required. When contacting a lacquer manufacturer, complete information concerning the application should be supplied. Information such as the cellulosic plastic that is to be used, its formula number and percent plasticizer, and whether a weather-resistant lacquer is required will aid the lacquer manufacturer in selecting the proper lacquer for the particular application.

As in solvent polishing, when lacquers are used on cellulosic articles that contain molded-in strains, release of the strains by the lacquer solvents frequently cause a wrinkle or orange-peel surface. For this reason, it is important that articles to be lacquered be as strain-free as possible. This usually can be accomplished by careful control of molding conditions and by proper mold design.

Sometimes a humidity blush occurs when articles are lacquered in a humid atmosphere. This usually can be overcome by adding a small amount of drying retarder such as Eastman PM acetate or other slow-drying active solvent to the lacquer.

Lacquer manufacturers include:

- E.I. duPont de Nemours and Co. Inc.
1007 TR Market Street
Wilmington, DE 19898
U.S.A.
800-441-9442
(1) 302-774-2866
- Morton International Inc.
2701 East 170th Street
Lansing, IL 60438
U.S.A.
(1) 708-474-7000
- Randolph Products Company, N.W.
12th Street Box 830
Carlstadt, NJ 07072-0830
U.S.A.
(1) 201-438-3700
- Red Spot Paint and Varnish Company
P.O. Box 418
Evansville, IN 47703
U.S.A.
(1) 812-428-9100
- Schwartz Chemical Company, Inc.
50-01 Second Street
Long Island City, NY 11101-5703
U.S.A.
(1) 718-784-7595
- The Sherwin-Williams Company
101 Prospect Avenue
Cleveland, OH 44115
U.S.A.
(1) 216-566-2000

Cementing

Tenite acetate can be cemented to Tenite acetate, and Tenite butyrate, and Tenite propionate can be cemented to themselves or to each other, in bonds as strong as the pieces being joined.

In cementing any of these plastics, it is necessary that the following precautions be observed.

The surfaces to be joined must be clean. A slight film of oil, water, or polishing compound may cause poor bonding.

- The surfaces must be smooth and as well aligned as practicable.
- The solvent or cement must be sufficiently active to soften the surface to a depth that will allow a small amount of flow to occur when pressure is applied to the softened area.

Tenite™ cellulosic plastics Secondary fabrication techniques

Plastics made from wood pulp—a renewable resource *(Continued)*

- The solvent or cement must be of such composition that it will dry completely without blushing.
- Pressure must be applied until the cemented joint has set to the extent that no movement occurs when the pressure is released.
- Subsequent finishing operations must be delayed until substantially all of the residual solvent has dissipated.

Two types of cementing agents are in general use: those consisting of solvents only (solvent type) and those consisting of a cellulose ester or other polymer dissolved in a solvent blend (dope type). In general, when the surfaces to be cemented are in a single plane, the solvent type is used. When the surfaces are irregular or so located as to make solvent application difficult, the dope type is used.

Cementing techniques with solvents

Small articles with plane surfaces to be joined can be cemented satisfactorily by holding the articles together with one hand and applying the solvent along the edges of the joint with a hypodermic needle, medicine dropper, or small oil can, making sure that the solvent flows throughout the area to be cemented. The joined articles can be safely laid aside to dry soon after the solvent has been applied.

For large articles, the preferred method of cementing with a solvent is to immerse the surfaces to be joined in the solvent until the material is softened substantially, then clamp and hold them in position until the bond has set. A convenient method of application is to hold the article so that the surfaces to be cemented just touch the solvent. This can be done by maintaining a constant level of solvent in a shallow pan and supporting the article on a pad of polyurethane foam or felt. The pad acts as a wick, thus allowing light contact of the article with the solvent. If polyurethane foam is used, it is suggested that the pad consist of two layers, each about 6.4 mm (1/4 in.) thick. If a felt pad is used, a fine wire screen over the pad helps minimize contamination of the plastic surface with fibers from the felt.

To reduce the rate of solvent evaporation, the pad may be covered with a closed tray from which the top has been cut so that one or more of the articles to be joined will fit in the openings. When an article is removed for

joining, another is put in its place; thus the pad is kept fully enclosed most of the time.

To secure a bond as strong as the plastic articles themselves, it is necessary to substantially soften the edges to be joined and then clamp the articles together. This may cause the softened plastic to protrude at the joint. The protrusion can be removed (after the pieces have stood 24 to 48 hours to permit the residual solvent to dissipate) by suitable machining operations followed by polishing. If a high finish is desired, it may be necessary to ash the surface at the joint after it has been machined and before it is polished.

Solvents

Acetone is one of the most commonly used solvents for cementing cellulosic plastics. However, it is ordinarily not good practice to use acetone or other low-boiling solvents alone because they evaporate so quickly. Rapid evaporation of solvent is likely to cause blush—a white frosty appearance of the cemented joint. Also, low-boiling solvents may evaporate before they have had sufficient time to soften the surfaces and effect adhesion. By adding one or more solvents of higher boiling point to the low-boiling solvent, blushing can be avoided and evaporation loss reduced. Eastman PM acetate is used satisfactorily for this purpose. Naturally, addition of the higher-boiling solvent will increase the drying time of the cement.

A list of useful active solvents for Tenite acetate, butyrate, and propionate, in order of increasing boiling point, follows:

Solvent	Boiling point °C (°F)
Acetone	56.5 (133.7)
Methyl acetate	59.8 (139.7)
Ethyl acetate	77.1 (170.8)
Methylethyl ketone	79.7 (175.4)
Isopropyl acetate*	90.0 (194.0)
Butyl acetate*	126.0 (258.8)
Eastman PM*	121.0 (274.8)
Eastman PM acetate	150.0 (302.0)
Ethyl lactate	155.0 (311.0)
Cyclohexanone	156.0 (312.8)
Diacetone alcohol	166.0 (330.8)
Butyl lactate*	195.6 (384.0)

* Solvent for butyrate and propionate, but not acetate.

Tenite™ cellulosic plastics Secondary fabrication techniques
 Plastics made from wood pulp—a renewable resource (Continued)

Suitable solvent mixtures for cementing Tenite acetate to Tenite acetate and for cementing Tenite butyrate and Tenite propionate to themselves, and to each other, follow:

Tenite acetate	Tenite butyrate and Tenite propionate
70% Acetone 30% Ethyl lactate	70% Acetone 30% Eastman PM acetate
30% Ethyl acetate 40% Acetone 30% Ethyl lactate	80% Butyl acetate 20% Butyl lactate
70% Acetone 30% Eastman PM acetate	30% Acetone 50% Butyl acetate 20% Eastman PM acetate

If a considerable surface of solvent mixture is exposed in the cementing pan, an unequal rate of evaporation will cause a gradual accumulation of the higher-boiling constituent. This may be corrected by replenishing with a mixture proportionately richer in low-boiling constituents.

Cementing techniques with dopes

The preferred technique for cementing with dopes is to prepare the surfaces carefully, as previously discussed, then apply the cement with a brush or other mechanical applicator. It is frequently desirable to soften the surfaces to be joined by an application of undiluted solvent before applying the dope cement. In some cases, solvents alone can be used both to soften the surfaces and to form the bond. Dopes can also sometimes be used to serve both purposes, provided the viscosity is not too high. Suitable cements for Tenite acetate, butyrate, and propionate can be obtained by making a 10% solution of the plastic in one of the appropriate solvent mixtures described on page 15. Cements and thinners for use with cellulose are sold by:

- Scholle Corporation
 2300 West Point Avenue
 College Park, GA 30337
 U.S.A.
 800-535-2968
 (1) 404-761-0604
 Fax: (1) 404-559-8892

Cementing Tenite™ acetate, Tenite™ butyrate, and Tenite™ propionate to other materials

The effect of plasticizer migration should be determined before cementing articles made of Tenite™ acetate to other plastics. The plasticizers present in Tenite™ acetate are active solvents for cellulose nitrate, many alkyd-type lacquers, and a number of other thermoplastic materials. With higher plasticizer levels of acetate, the plasticizer will, in some cases, migrate to the other material and cause it to craze or become soft and, in extreme cases, tacky. This can sometimes be overcome by selecting either a lower plasticizer level in a particular acetate formula or a different formula with better plasticizer retention. All plasticizers used in Tenite™ acetate have a strong tendency to cause crazing of polystyrene and methyl methacrylate. Therefore, all assemblies of Tenite™ acetate with these materials should be tested at 38°C (100°F) and 80% relative humidity (or higher temperature and humidity if such is expected in actual service) to determine whether crazing results.

The plasticizers used in Tenite™ butyrate and Tenite™ propionate have less solvent action than those used in Tenite™ acetate, and they are present in much smaller proportions. Therefore, they have less tendency to migrate, especially in the lower plasticizer levels of butyrate and propionate. Thus, the effect of plasticizer migration may be greatly minimized, or overcome, by the use of the proper formula and plasticizer level of butyrate or propionate.

Tenite™ cellulosic plastics Secondary fabrication techniques

Plastics made from wood pulp—a renewable resource *(Continued)*

The following list of adhesive manufacturers is not complete but includes manufacturers whose adhesives have been tested or otherwise found satisfactory for use with Tenite™ cellulosic plastics. These manufacturers can supply adhesives for cementing Tenite™ acetate, butyrate, and propionate to themselves or other materials if all the available information is supplied concerning the application. The formula and plasticizer level of the cellulosic material should be given as well as the material that is to be joined to the plastic. Information concerning the environmental conditions that the cemented articles must withstand is also helpful.

- **Ferro Corporation**
1301 North Flora Street
Plymouth, IN 46563
U.S.A.
(1) 219-935-5131
- **Minnesota Mining & Mfg. Co.**
3M Center Drive
St. Paul, MN 55144-1000
U.S.A.
(1) 800-326-3550 U.S.A.
- **Pierce & Stevens Chemical Co.**
710 Ohio Street
Buffalo, NY 14203
U.S.A.
(1) 716-856-4910 U.S.A.
- **PPG Industries, Inc.**
Adhesive Products
5875 New King Court
Troy, MI 48098
U.S.A.
(1) 248-641-2000
- **RTG Armstrong Epoxy**
28 Norfolk Avenue
S. Easton, MA 02375
U.S.A.
(1) 508-230-8070
- **Schwartz Chemical Co., Inc.**
50-01 Second Street
Long Island City, NY 11101
U.S.A.
(1) 718-784-7595

Bonds of only limited strength are obtained when acetate, butyrate, and propionate are cemented to polystyrene and vinyl plastics. For this reason, it is suggested that a mechanical method of assembly be used for joining these materials when possible.

When acetate, butyrate, and propionate are cemented to other plastics or to nonplastic materials, the bond generally is not equal to that obtained when like materials are joined. A mechanical method of assembly is preferred. However, bonds suitable for some applications can be obtained by proper choice of cement, and formula and plasticizer level of the cellulosic plastic.

Other assembly methods

Welding

Although cementing is the preferred method for joining cellulosic plastics to themselves, they can sometimes be welded to themselves by conventional welding techniques used for thermoplastics. Spin welding, ultrasonic welding, and vibratory welding are the most widely used of the various techniques. These welding techniques are similar in that they all utilize frictional heat to achieve welding, but they differ in the manner in which the frictional heat is generated.

In spin welding, one section of the article to be welded is rotated against the other section, which is held stationary. The rubbing contact at the joint interface generates sufficient heat to form a thin layer of melted plastic. The rotating section is then stopped, and the two sections are held together under pressure until the melted plastic solidifies.

Spin welding is possible only when the joints are circular in cross-section, but the article itself does not have to be circular. The joint can be designed to include a flash trap that hides the flash and practically eliminates additional finishing. Consideration must also be given to methods of holding the sections in the equipment and for rotating one section. Special lugs for this purpose are usually designed into the article. Variables involved in spin welding are surface speed, contact pressure, and contact time. Sufficient frictional heat to achieve welding can be generated in a few seconds. When the rotation is stopped,

Tenite™ cellulosic plastics Secondary fabrication techniques

Plastics made from wood pulp—a renewable resource *(Continued)*

the melted plastic in the joint solidifies rapidly. Orientation of one component to another is possible with servo-type equipment. Generally, contact pressure of 0.07 to 1.38 MPa (10 to 200 lb/in.²) is required for only a few seconds to achieve a successful weld. Excessive heating should be avoided to prevent plasticizer exudation or joint embrittlement.

Spin welding can be done on equipment manufactured for this purpose or on a modified drill press or lathe.

The conditions to be used for spin welding cellulosic plastics should be determined for each individual application, since conditions will vary with the type of equipment used and the geometry of the article to be welded. In ultrasonic welding, the frictional heat is generated by low-amplitude, high-frequency mechanical vibrations (about 15–40 KHz) at the interface of the plastic sections to be welded.

An ultrasonic-welding system consists of a source of electrical energy, a transducer for converting electrical energy into mechanical vibrations, and a device (generally called a horn) for transmitting the mechanical vibrations to the article to be welded. The mechanical vibrations travel through the plastic to the interface where the energy is dissipated in the form of heat.

Thin-gauge cellulosic plastics can be welded by the contact or near-field method, in which the vibrations travel less than 25 mm (1 in.) from the horn to the joint interface. Far-field welding, in which the vibrations travel for a distance greater than 25 mm (1 in.) from the horn to the joint interface, sometimes can be used satisfactorily for welding thick-walled cellulosic parts. The time required for ultrasonic welding of cellulosic plastics usually ranges from 0.5 to 2 seconds.

The geometry of articles that can be welded by ultrasonic techniques is not as limited as it is for spin welding. However, the design of plastic articles should be given careful consideration if they are to be ultrasonically welded, since certain design features can be utilized to facilitate welding and minimize finishing. Higher plasticizer levels normally give best results with this method.

Manufacturers of ultrasonic welding equipment should be contacted for suggestions on section and joint design.

Sources for ultrasonic welding equipment include:

- **Branson Ultrasonic Corporation**
Eagle Road
Danbury, CT 06810
U.S.A.
(1) 203-796-0400
- **DuKane Ultrasonics**
2900 Dukane Drive
St. Charles, IL 60174
U.S.A.
(1) 708-584-2300
- **Sonics & Materials Inc.**
53 Church Hill Road
Newtown, CT 06470
U.S.A.
(1) 203-270-4600
- **Sonobond Ultrasonics**
1191 McDermott Drive
West Chester, PA 19380
U.S.A.
(1) 610-696-4710

In vibration welding, the frictional heat is generated by pressing together the surfaces to be welded and vibrating the surfaces through a small relative displacement in the plane of the joint. The equipment used in vibratory welding is simple.

The vibration welder operates at frequencies up to 240 Hz. The amplitude of displacement can be varied from (0.035 to 0.020 in.). Pressure on the joint should be in the range of 1.38 to 1.73 MPa (200 to 250 psi). Cycle time will generally be between 2 and 3 seconds plus approximately 1 second hold time to allow the welded joint to cool under pressure before being released. This is a slightly longer cycle than that required for ultrasonic welding, but it is much shorter than the cycles required for welding on a hot plate or for solvent cementing. The joint strength of vibratory welded parts approximates the strength of the solid cellulosic material.

The advantages of vibration welding are that large parts, both rectangular and circular, may be welded; and many plastic materials that cannot be welded by ultrasonic welding can be welded satisfactorily by vibratory welding.

Tenite™ cellulosic plastics Secondary fabrication techniques Plastics made from wood pulp—a renewable resource *(Continued)*

Lower plasticizer levels normally give best results with vibratory welding. Multiple parts may also be joined in one cycle. This process does not require the transmission of energy (i.e., ultrasonics) therefore a wide range of products can be assembled.

There are several manufacturers of vibratory welding equipment. The evaluations Eastman conducted on Tenite™ cellulosic plastics were on welding equipment from Branson UltraSonics Corp., Danbury, Connecticut.

Mechanical assembly of Tenite plastic to other materials

It is important to determine the effect of plasticizer migration from the plastic to the other material; for instance, the quality of the bond could be affected.

Where possible, mechanical methods of assembly are generally more satisfactory than cementing. Threaded inserts may be molded into articles, and the articles assembled to parts made of other materials by standard or speed-type nuts. Also, the plastic article may be molded with a slight undercut, which can be “jumped” from the mold at ejection. The undercut will serve adequately as an anchor when forced into a mating depression in the surface of the article to which it is to be attached.

Machine screws may be used in holes that are either tapped, molded, or drilled directly into the article. In some cases, this method of assembly may not be satisfactory because of the tendency of plastics to flow slightly when stress is applied to small areas for long periods of time. The cold flow may eventually cause the tension on the screw to relax. However, where only reasonable loads are imposed on the screw, this method is satisfactory. Self-tapping or thread-forming screws are preferred because of the intimate metal-to-plastic contact, which provides high strength. A variation of these is the drive screw, which is intended only for permanent assemblies.

Tenite acetate, Tenite butyrate, and Tenite propionate can be easily swaged by the use of pressure and a heated tool. This characteristic, in some instances, permits the assembly of articles without the use of screws or other fasteners.



**Eastman Chemical Company
Corporate Headquarters**

P.O. Box 431
Kingsport, TN 37662-5280 U.S.A.

Telephone:
U.S.A. and Canada, 800-EASTMAN (800-327-8626)
Other Locations, (1) 423-229-2000
Fax: (1) 423-229-1193

Eastman Chemical Latin America

9155 South Dadeland Blvd.
Suite 1116
Miami, FL 33156 U.S.A.

Telephone: (1) 305-671-2800
Fax: (1) 305-671-2805

Eastman Chemical B.V.

Fascinatio Boulevard 602-614
2909 VA Capelle aan den IJssel
The Netherlands

Telephone: (31) 10 2402 111
Fax: (31) 10 2402 100

**Eastman (Shanghai) Chemical
Commercial Company, Ltd. Jingan Branch**

1206, CITIC Square
No. 1168 Nanjing Road (W)
Shanghai 200041, P.R. China

Telephone: (86) 21 6120-8700
Fax: (86) 21 5213-5255

Eastman Chemical Japan Ltd.

MetLife Aoyama Building 5F
2-11-16 Minami Aoyama
Minato-ku, Tokyo 107-0062 Japan

Telephone: (81) 3-3475-9510
Fax: (81) 3-3475-9515

Eastman Chemical Asia Pacific Pte. Ltd.

#05-04 Winsland House
3 Killiney Road
Singapore 239519

Telephone: (65) 6831-3100
Fax: (65) 6732-4930

www.eastman.com

Although the information and recommendations set forth herein are presented in good faith, Eastman Chemical Company makes no representations or warranties as to the completeness or accuracy thereof. You must make your own determination of their suitability and completeness for your own use, for the protection of the environment, and for the health and safety of your employees and purchasers of your products. Nothing contained herein is to be construed as a recommendation to use any product, process, equipment, or formulation in conflict with any patent, and we make no representations or warranties, express or implied, that the use thereof will not infringe any patent. NO REPRESENTATIONS OR WARRANTIES, EITHER EXPRESS OR IMPLIED, OF MERCHANTABILITY, FITNESS FOR A PARTICULAR PURPOSE, OR OF ANY OTHER NATURE ARE MADE HEREUNDER WITH RESPECT TO INFORMATION OR THE PRODUCT TO WHICH INFORMATION REFERS AND NOTHING HEREIN WAIVES ANY OF THE SELLER'S CONDITIONS OF SALE.

Safety Data Sheets providing safety precautions that should be observed when handling and storing our products are available online or by request. You should obtain and review available material safety information before handling our products. If any materials mentioned are not our products, appropriate industrial hygiene and other safety precautions recommended by their manufacturers should be observed.

© Eastman Chemical Company, 2013. Eastman and Tenite are trademarks of Eastman Chemical Company.